



Bray[®]

SERIES 22/23 Wafer/Lug
2" - 24" (50mm - 600mm)

HPV-HIGH PERFORMANCE VALVE

PTFE, CONDUCTIVE PTFE AND UHMWPE

**The Bray® HPV
High Performance Valve
PTFE, Conductive PTFE &
UHMWPE 150psi (10 bar)**

For Corrosive Applications
in the chemical industry which require PTFE,

High Temperature Applications
up to 392°F (200°C) with PTFE,

Conductive Applications
where PTFE Electrostatic Discharge (ESD) protection is required,

Abrasive Applications
involving chemicals or temperatures where UHMWPE is the preferred material.

The Series 22/23 HPV line of butterfly valves sets the new standard of reliability and innovation. Extensive field research and engineering have developed this state-of-the-art design which provides excellent shut off protection (bubble-tight shut off) and high C_v values.

The HPV is crafted in a variety of materials such as PTFE, Stainless Steel, UHMWPE and special alloys to fit a wide range of customer requirements. As with all Bray's products, precision manufacturing and exceptional quality remain the keys to a proven record of long service life.

DISC (A) The HPV PTFE disc has 1/8" (3 mm) minimum thickness of pure, virgin PTFE encapsulated over the following metals:

- 2" - 12" valves, PTFE encapsulated over 316 stainless steel
- 14" - 24" valves, PTFE encapsulated over 17-4 PH SS.

A 316 stainless steel disc is also available in all valve sizes. The disc design allows for a higher flow area than other typical PTFE valves. All discs are fully certified (DIN 50049 3.1.B) and marked accordingly for traceability.

BODY (B) Bodies are two piece wafer or lug style and are epoxy coated. All bodies meet full ANSI Class 150 and DIN 3840 pressure ratings for hydrostatic requirements. Body materials are fully certified (DIN 50049 3.1.B) and marked accordingly for traceability.

NECK (C) An extended neck design in all valve sizes allows for 2" of piping insulation and provides easy access for mounting actuators.

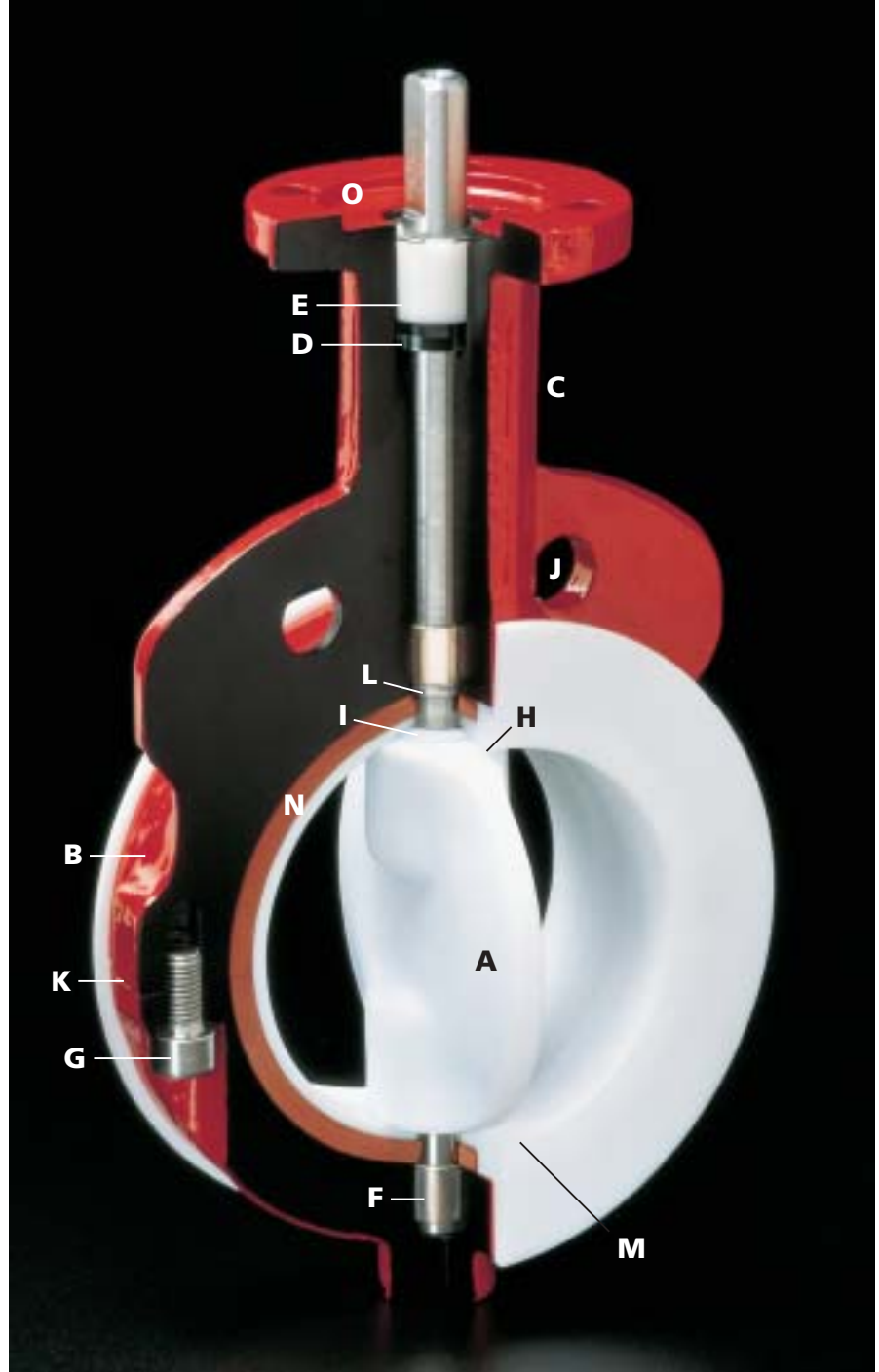

UPPER STEM SEAL (D) The upper stem seal serves to keep any environmental contaminants from entering the stem bore. Material is Buna-N as the standard or FKM as an option.

TOP STEM BUSHING (E) A top stem bushing is provided to absorb actuator side thrusts and is acetal as standard or PTFE as an option. The stainless steel retaining ring at the top of the valve retains the bushing in position, even when the valve is installed upside down.

BEARINGS (F) Two PTFE impregnated steel bearings are provided for precision alignment of the upper and lower stem.

BODY BOLTS (G) are 316 Stainless Steel material.

BRAY'S UNIQUE STEM SEALING SYSTEM FEATURING THE SEAL CAPSULE DESIGN

PRIMARY SEAL (H) The primary seal is achieved by an interference fit between the extra wide disc hubs and specially contoured seat.

SEAL CAPSULE (I) (SECONDARY SEAL)

One key feature of the Bray HPV is the patented *Seal Capsule* that forms the secondary stem seal. This capsule fully isolates the valve body and stem from the line media. The *Seal Capsule* is made of a virgin PTFE enclosing the internal energizer. The capsule fits into grooves machined in the upper and lower disc hubs. When compressed between the disc and seat during assembly, the capsule becomes energized, exerting both upward and downward pressure on disc and seat surfaces.

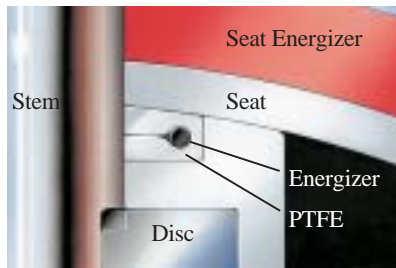

The Energized Seal Capsule

This sealing design is simple, reliable and proven, yet it requires much fewer components than other valves that utilize large metal springs to squeeze the packing against the shaft.

FLANGE LOCATING HOLES (J) Locating holes in the wafer version provide quick and precise alignment during valve installation, eliminating disc interference with adjacent pipe I.D.

BODY SEALS (K) (Bidirectional)

Reinforced PTFE gaskets are placed between the body halves. These seals eliminate contamination from external environmental conditions and potential leak path from the line media.

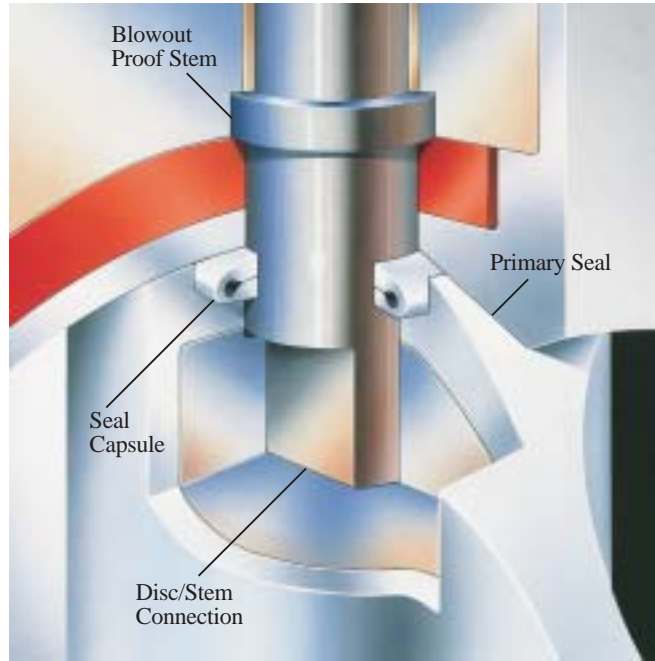
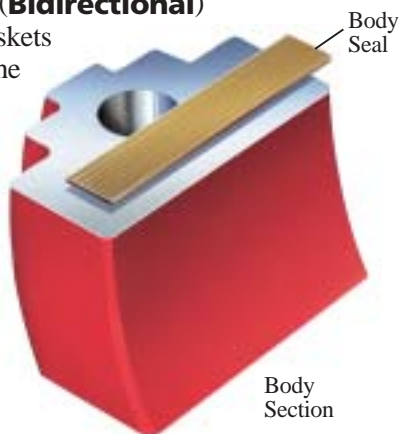

BLOWOUT PROOF STEM (L) A shoulder has been machined into the upper stem. The upper stem is coupled to the valve disc by Bray's unique double "D" connection. The stem and the disc are pressed together during assembly to become one part, thus the design is a positive stem-to-disc drive connection. Both upper and lower stem materials are 17-4 PH Stainless Steel.

SEAT DESIGN (M) The unique Bray Series 22/23 HPV seat design reduces seating/unseating torque and, at the same time, reduces wear on the contacting parts.

Utilizing state-of-the-art engineering, optimal computer designed curvatures are machined into the inner seat area. The curvatures minimize contact forces between the disc and seat as the disc approaches, or opens from, the closed position. This unique seat geometry permits lower torques and reduces seat wear.

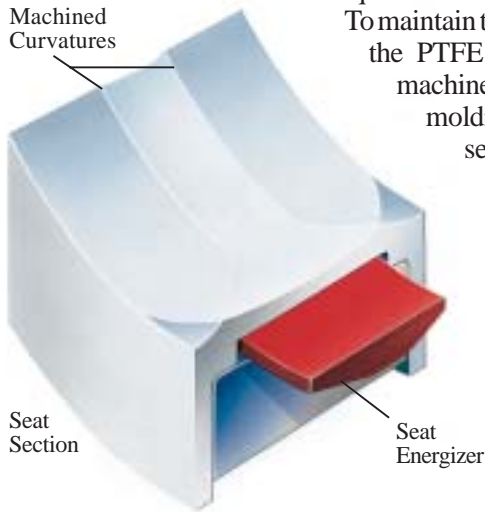

To maintain the proper shape, the PTFE seats are fully machined after the initial molding process. All seats are mill certified (DIN 50049 3.1.B) and are marked accordingly for traceability.

SEAT ENERGIZER (N) A resilient seat energizer extends completely around the seat, including the disc hub. This provides uniform force sufficient for bubble-tight shut off. The standard energizer material is silicone, FKM is available as an option.

ACTUATOR MOUNTING FLANGE AND STEM CONNECTION (O) Designed to comply with ISO 5211 for direct mounting of Bray power actuators and manual operators.

VIRGIN PTFE SPECIFICATIONS

All Bray PTFE seats and encapsulated discs are molded from pure, virgin PTFE material to the following specifications:

Item	Minimum
Thickness	3 mm
Specific Gravity	2.16
Crystallinity	68%

PTFE's inherent molecular bonding strength gives an extremely good chemical, high temperature and tear resistance. These properties combined with Bray's stringent material specifications provide optimum protection against permeation of the line media. This protection is far superior to PFA or FEP materials offered by other manufacturers.

PTFE also features a low coefficient of friction, thus reducing valve operating torques. PTFE lined discs and

seats are ideal for high pressure use in chemical, high purity water, food, pharmaceutical and other sanitary industries.

PRESSURE RATINGS For bi-directional bubble-tight shut off, disc in closed position:

PTFE Molded Disc with PTFE Seat and 316 SS, Hastelloy® C and Titanium Discs with PTFE Seat
2"-24" 150psi – 50mm-300mm 10 bar

TEMPERATURE/PRESSURE DIAGRAM

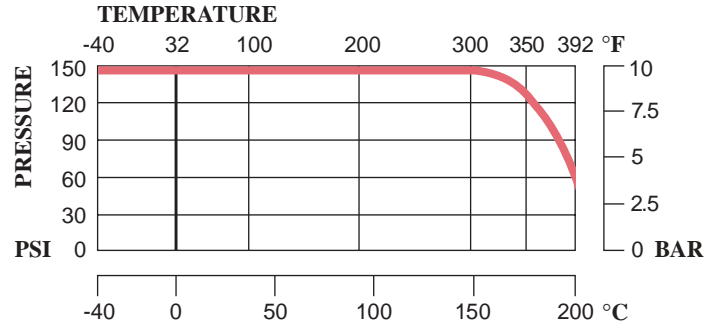

CONDUCTIVE PTFE

Bray Conductive PTFE seats and discs are available for installation in areas of the plant where explosion protection is important. This material was designed to prevent harmful electrostatic discharge (ESD). The conductivity has been obtained by the controlled addition of no more than 1.2% carbon. For the ultimate in safety and reliability, Bray has combined ESD protection and the excellent chemical resistance properties of PTFE. The conductive PTFE seat and the disc is 1/8" (3 mm) minimum thickness, providing optimum protection against permeation of the line media.



UHMWPE Seat

Conductive PTFE Seat and Disc

UHMWPE

HPV seats and discs are available in UHMWPE, the ideal choice for highly abrasive chemical applications. The natural ability of the UHMWPE's high molecular weight to repel solids prevents in-line particles from damaging the valve's seat surfaces. The Bray UHMWPE seat offers the same machined curvatures and fully extending seat energizer as the PTFE seat. The UHMWPE seat and disc feature exceptional chemical resistance and

a 150 psi pressure rating. These properties and features combine to greatly extend the life of the valve, and make the HPV UHMWPE seat and disc the economical and high performance choice for abrasive chemical services.

PRESSURE RATING For bi-directional bubble-tight shut off, disc in closed position:

UHMWPE Molded Disc with UHMWPE Seat
Stainless Steel Disc with UHMWPE Seat
2"-12" 150 psi – 50mm-300mm 10 bar
For larger valve sizes consult the Bray factory.

TEMPERATURE RATING Maximum: 185°F (85°C)
Minimum: -0°F (-18°C)

VACUUM RESISTANT SEATS

Plant applications with vacuum and temperature fluctuations place unique demands on valve seats. When plant vacuum decreases and operating temperature increases, substantial stress is placed on typical valve seat material. This stress is increased during temperature fluctuations. The standard HPV PTFE seats have been designed for low and medium vacuum service. Special HPV PTFE seats are available for high vacuum service. Consult Bray factory for further information.

INTERNATIONAL FLANGE COMPATIBILITY

Bray's Series 22 valve is a wafer version with flange locating holes, and the Series 23 is the companion lug version for full rated dead-end service.

A major design advantage of Bray valve product lines is international compatibility. These valves are compatible with most world flange standards. In addition the valves are designed to comply with ISO 5752 face-to-face and ISO 5211 actuator mounting flanges. Therefore, one HPV valve design can be used in many different world markets.

Bray's complete range of valves, accessories and parts, all with worldwide compatibility offers the best in uniformity, economy and high performance in the industry today.

DIRECT MOUNTING

Due to a modular concept of design, all Bray handles, manual gear operators, pneumatic and electric actuators mount directly to Bray valves. No brackets or couplings are required.



POLYESTER COATING

As its standard product Bray offers Series 22/23 HPV valve bodies with a polyester coating, providing excellent corrosion and wear resistance to the valve's body surface. The Bray polyester coating is a hard, gloss red finish.

Chemical Resistance – resists a broad range of chemicals including: dilute aqueous acids and alkalis, salts, salt spray, petroleum solvents, alcohols, greases and oils. Offers outstanding resistance to humidity and water.

Weatherability – outdoor proven resistant to ultra-violet radiation.

Abrasion Resistance – excellent

Impact Resistance – withstands impact without chipping or cracking.

FACTORY TESTING

Extensive testing has proven the Bray PTFE seat maintains a bubble-tight seal during temperature fluctuations throughout the pressure and temperature range of the valve. All Bray valves are tested to 110% of full pressure rating before shipment. Conductivity and other tests may be performed upon customer request.

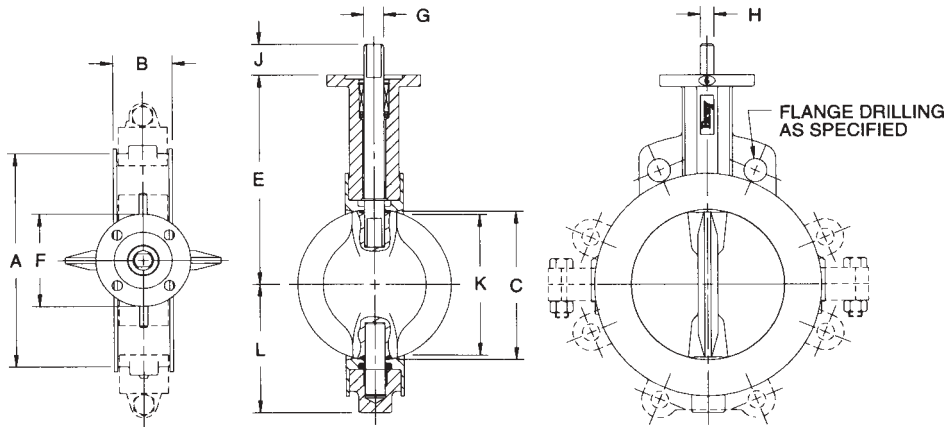

DIMENSIONS Series 22

Valve Size		A	B	C	E	F	Mounting Flange Drig.			G	H*	J	K	L
ins	mm						BC	No. Holes	Hole Dia.					
2	50	3.88	1.69	2.00	5.50	3.54	2.76	4	.39	.55	.39	1.25	1.13	2.22
2 1/2	65	4.38	1.81	2.50	6.00	3.54	2.76	4	.39	.55	.39	1.25	1.77	2.47
3	80	5.00	1.81	3.00	6.25	3.54	2.76	4	.39	.55	.39	1.25	2.44	2.81
4	100	6.25	2.05	4.00	7.00	3.54	2.76	4	.39	.63	.43	1.25	3.48	3.56
5	125	7.38	2.20	5.00	7.50	3.54	2.76	4	.39	.75	.51	1.25	4.53	4.28
6	150	8.50	2.20	5.75	8.00	3.54	2.76	4	.39	.75	.51	1.25	5.35	4.78
8	200	10.62	2.36	7.75	9.50	5.91	4.92	4	.57	.87	.63	1.25	7.43	6.03
10	250	12.75	2.68	9.75	10.75	5.91	4.92	4	.57	1.18	.87	2.00	9.42	7.41
12	300	14.88	3.07	11.75	12.25	5.91	4.92	4	.57	1.18	.87	2.00	11.39	8.41
14	350	17.05	3.07	13.25	13.62	5.91	4.92	4	.57	1.38	.39x.39	2.00	13.00	9.93
16	400	19.21	4.02	15.25	14.75	5.91	4.92	4	.57	1.38	.39x.39	2.00	14.75	10.75
18	450	21.12	4.49	17.25	16.00	8.27	6.50	4	.81	1.97	.39x.47	2.50	16.65	12.00
20	500	23.25	5.00	19.25	17.25	8.27	6.50	4	.81	1.97	.39x.47	2.50	18.73	13.72
24†	600	33.00	5.68	23.25	19.50	8.27	6.50	4	.81	2.50	.62x.62	4.00	22.69	17.77

Series 23

Lug Bolting Data		
BC	No. Holes	Threads UNC-2B
4.75	4	5/8-11
5.50	4	5/8-11
6.00	4	5/8-11
7.50	8	5/8-11
8.50	8	3/4-10
9.50	8	3/4-10
11.75	8	3/4-10
14.25	12	7/8-9
17.00	12	7/8-9
18.75	12	1-8
21.25	16	1-8
22.75	16	1 1/8-7
25.00	20	1 1/8-7
—	—	—

WEIGHTS

Valve Size		Series 22	Series 23
ins	mm		
2	50	6.5	8.0
2 1/2	65	7.5	10.0
3	80	8.5	11.0
4	100	13.5	17.5
5	125	16.0	21.0
6	150	20.5	28.5
8	200	38.5	51.5
10	250	62.0	76.0
12	300	76.0	116.0
14	350	125.0	148.0
16	400	180.0	218.0
18	450	240.0	273.0
20	500	320.0	368.0
24	600	—	500.0

Weights are in lbs.

*Keyway is applicable on valve sizes 14"-24".

†24" valve available only as a double flanged Series 23, applicable for Dead End service.

SEATING/UNSEATING TORQUES (Lb.-Ins.) SERIES 22/23 PTFE FOR GENERAL SERVICE

Valve Size		Full-Rated Pressure Valves
ins	mm	150 psi (ΔP)
2	50	288
2 1/2	65	350
3	80	560
4	100	720
5	125	960
6	150	1300
8	200	2402
10	250	3840
12	300	5812
14	350	8000
16	400	11000
18	450	15500
20	500	19300
24	600	30500

TO USE TORQUE CHART, NOTE THE FOLLOWING:

- 1) Valve Torque Rating – Bray has classified valve torque ratings according to 3 types: non-corrosive lubricating service, general service, and severe service. Torques listed are for general services. Consult Bray for torque information corresponding to specific application.
- 2) These Seating/Unseating Torque values are to be used for all differential pressures up to 150 psi.
- 3) Dynamic Torque values are not considered. See Technical Bulletin No. 1002 for evaluation of Dynamic Torque values vs. Seating/Unseating Torque values.
- 4) Do not apply a safety factor to above torque values when determining actuator output torque requirement.
- 5) For 3 way assemblies where one valve is opening and other is closing, multiply torque by 1.5 factor.

VELOCITY LIMITS

For On/Off Services:
Fluids – 30 ft/sec (9m/s)
Gases – 175 ft/sec (54m/s)

FLANGE REQUIREMENTS

Bray Series 22/23 HPV valves are designed for installation between ANSI Class 125/150 weld-neck or slip-on flanges, BS 10 Tables D and E, BS 4504 NP 10/16, DIN ND 10/16, AS 2129 and JIS10, either flat faced or raised faced. The Series 22/23 is compatible with most commonly used metal and plastic weld-neck and slip-on flanges. Type C metal stub-end and certain wide-grooved plastic flanges are not recommended. Please consult factory for specific applications.

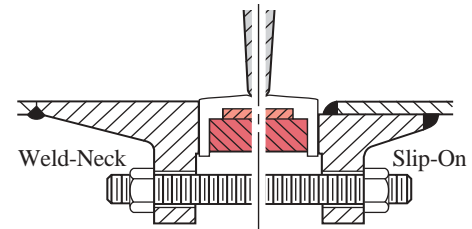

C_v VALUES – VALVE SIZING COEFFICIENT

Valve Size		Disc Position (degrees)								
ins	mm	90°	80°	70°	60°	50°	40°	30°	20°	10°
2	50	146	115	85	62	44	27	16	7	1
2 1/2	65	300	235	176	110	69	43	24	11	1
3	80	586	413	286	158	98	61	35	15	2
4	100	1051	812	503	285	177	109	62	27	3
5	125	1814	1297	798	440	276	171	98	43	5
6	150	2576	1737	1048	580	364	226	129	57	6
8	200	4354	3142	1908	1111	698	424	242	104	12
10	250	6834	4976	3004	1761	1105	672	385	165	20
12	300	10090	7392	4420	2591	1604	975	559	241	29
14	350	12880	9350	8700	3300	2100	1280	720	300	35
16	400	16900	12320	7500	4400	2750	1650	850	350	45
18	450	21600	15600	9830	5700	3600	2100	1200	510	55
20	500	27500	19900	12200	7100	4480	2700	1550	650	80
24	600	34800	28500	18900	11300	7000	4600	2450	1000	180

C_v is defined as the volume of water in U.S.G.P.M. that will flow through a given restriction or valve opening with a pressure drop of one (1) p.s.i. at room temperature. Recommended control angles are between 25°–70° open.

HOW TO ORDER Standard Part Number: Series - Size - Base Part - Material Code

Series	22 – Wafer style body	23 – Lug style body
Size	0200 (for 2") through 2400 (for 24")	
Base Part	11086 – Wafer Full Pressure Rating – 150 psi	11010 – Lug Full Pressure Rating – 150 psi
	11091 – Above plus Fugitive Emissions Tap	11074 – Above plus Fugitive Emissions Tap

Material Codes

386	2" - 12"	PTFE seat, PTFE encapsulated 316 Stainless Steel disc, 17-4 PH SS stem
33M	14"-24"	PTFE seat, PTFE encapsulated 17-4 PH Stainless Steel disc, 17-4 PH Stainless Steel stem
387	2" - 24"	PTFE seat, 316 Stainless Steel disc, 17-4 PH Stainless Steel stem
30E	2" - 12"	UHMWPE seat, UHMWPE encapsulated 316 Stainless Steel disc, 17-4 PH SS stem
30F	8" - 12"	UHMWPE seat, UHMWPE encapsulated Ductile Iron disc, 17-4 PH SS stem
30D	2" - 12"	UHMWPE seat, 316 Stainless Steel disc, 17-4 PH SS stem
30H	2" - 12"	Conductive PTFE seat, Conductive PTFE encapsulated 316 SS disc, 17-4 PH SS stem

Consult factory for additional trim options, including Hastelloy, Titanium and Viton energizers.

Example: 6" lug style, PTFE molded seat and encapsulated disc butterfly valve: 23-0600-11010-386

HPV COMPONENTS & MATERIAL SELECTION

Item Name	Material	Designation
1 Body	Ductile Iron	ASTM A395
	Stainless Steel	ASTM A351 CF8M
	Carbon Steel	ASTM A216 WCB
2 Disc	Stainless Steel	ASTM A351 CF8M
	PTFE/SS 2"-12"	PTFE/A351 CF8M
	PTFE/SS 14"-24"	PTFE/A547-CB7Cu1
	UHMWPE/SS 2"-12"	UHMWPE/A351 CF8M
	UHMWPE/DI 8"-12"	UHMWPE/A536 Gr 65-45-12
	Hastelloy®	ASTM A494 CW2M
	Titanium	
3 Seat	PTFE	—
	Conductive PTFE	—
	UHMWPE	—
4 Upper Stem	17-4 PH SS	ASTM A-564-T630/H900
5 Lower Stem	17-4 PH SS	ASTM A-564-T630/H900
6 Bushing	Acetal	—
	PTFE	—
7 Upper Stem Seal	Buna N	—
	FKM*	—
8 Seal Capsule (2)	PTFE/FKM	—
9 Bearing (2)	PTFE/St.	—
10 Seat Energizer (2)	Silicone	—
	FKM	—
11 Cap Screw (2)	Stainless Steel	ASTM F593-91, GR 1
12 Retainer	Stainless Steel	ASTM F593-91, GR 1
13 Body Seal (2)	Reinforced PTFE	—
14 ID Tag	Stainless Steel	—

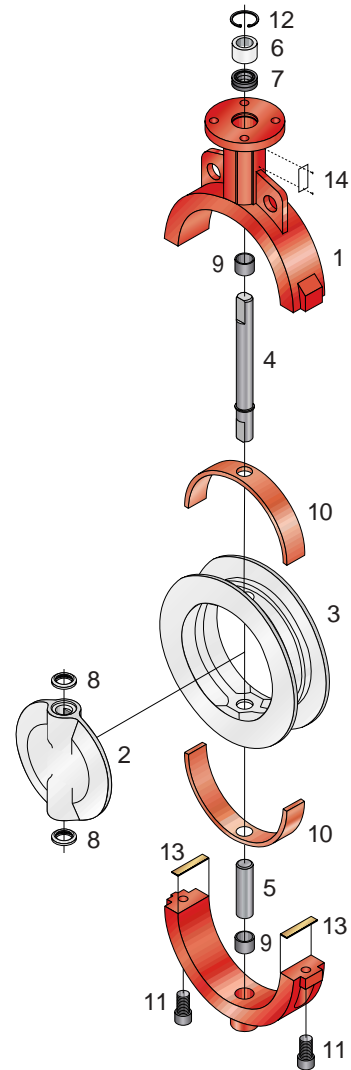

ACCESSORIES

A tapped port can be provided in the body neck below the stem seal to connect leak detectors or instrumentation.

A Grounding Cable is offered to protect against static charge build-up. The cable mounts to the valve body.

CLASS 1000 CLEANROOM

Bray offers a Class 1000 Cleanroom facility for cleaning, assembly, testing and bagging of Bray valves to be used in high purity applications. By performing these procedures in a cleanroom, Bray delivers valves which can be placed directly into high purity systems without the need for any component cleaning in the field. The inherent characteristics of the HPV are further enhanced by processing in this facility.

This on-site facility meets the specifications of Federal Standard 209E for Class 1000 airborne particulate cleanliness.

Bray Series 22/23 valves which have been processed in the cleanroom



are suitable for applications in semiconductor, chemical, pharmaceutical, food and other industries which have standards for high purity. Specific services include ultra pure water, deionized water, ultra pure chemicals, oxygen or any service where the control of contaminants is an important criteria.

*FKM is the ASTM D1418 designation for Fluorinated Hydrocarbon Elastomers (also called Fluoroelastomers).

Hastelloy® is a registered trademark of Haynes International, Inc.

Bray Controls is committed to world leadership in the fluid process industry. Our leadership is based on the highest quality products, innovative engineering and the most efficient customer service. Bray Controls was founded on the philosophy that our customers and personnel are our most valuable assets.

With years of field application experience and customer cooperation, we have designed state-of-the-art products with features and benefits previously unavailable. Bray offers a full line of resilient seated butterfly valves for

economical, industrial, chemical and sanitary applications.

Bray valves are complemented by a fully modular component system of manual operators, pneumatic and electric actuators and Brayline accessories.

Bray's product lines are in service in a wide range of industries worldwide – a few industries include Chemical, Pharmaceutical, Petroleum Refining, Microelectronics, Pulp and Paper, Water and Waste Water Treatment, Brewing, Food Processing, Beverages, Power Generation, Mining, Textile and HVAC.



World Headquarters, Houston, Texas, U.S.A.

Worldwide Sales and Services Network

Division Locations



Distribution Locations

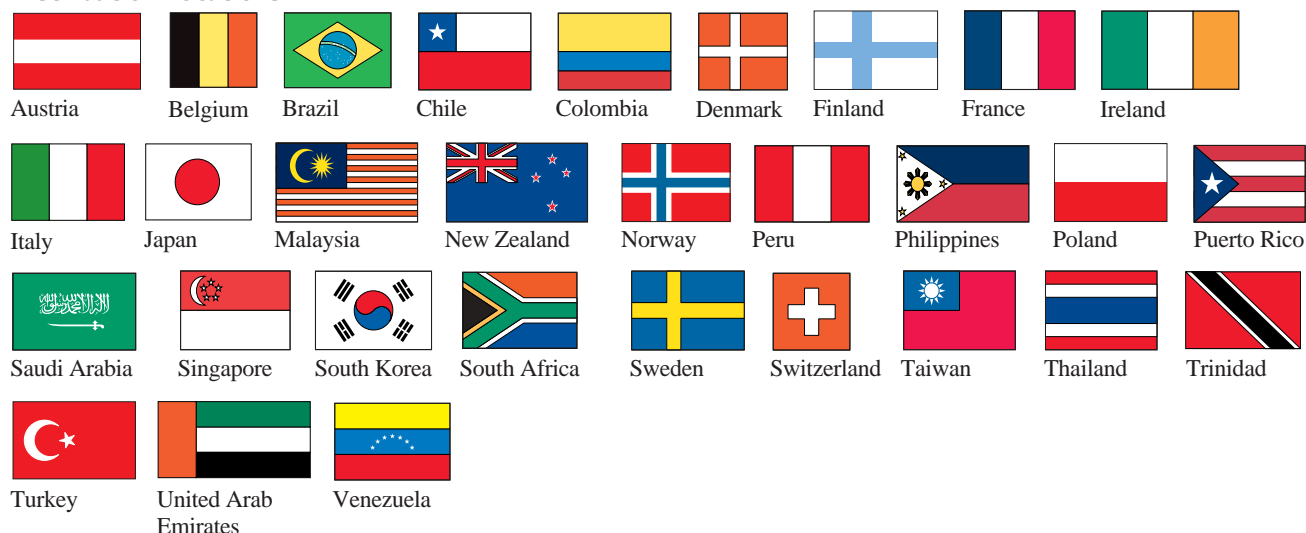

All statements, technical information, and recommendations in this bulletin are for general use only. Consult Bray representatives or factory for the specific requirements and material selection for your intended application. The right to change or modify product design or product without prior notice is reserved.

United States patent number 5,314,165.
Other patents issued and applied for worldwide.
Bray® is a registered trademark of Bray International Inc.



A Division of BRAY INTERNATIONAL, Inc.
13333 Westland East Blvd. Houston, Texas 77041
281.894.5454 FAX 281.894.9499 www.bray.com

© 2002 Bray International. All rights reserved.