



A SUBSIDIARY OF / UNE FILIALE DE BRAY INTERNATIONAL INC.

INSTALLATION AND MAINTENANCE MANUAL
FOR
CHECK RITE WAFER TYPE SWING CHECK VALVES
MI-200
SIZES 1½" - 42"
ANSI SERIES: 125 - 2500
MODELS 201, 202, 203, 205, 210, 211, 212, 260

4 June 2002

Ritepro Corporation, 12200 Albert Hudon, Montreal, Quebec, Canada, H1G 3K7
Tel: (514) 324-8900 • Fax: (514) 324-9525
Web Site: www.ritepro.com • Email: sales@ritepro.com



Table of Contents

Subject	Page
1.0 Introduction to Check Rite Wafer Type Swing Check Valves	2
2.0 Description of Check Rite Valves	2
3.0 Dis-Assembly and Assembly Instructions for Check Rite Wafer Type Swing Check Valves	4
4.0 Installation Instructions	6
5.0 Maintenance Requirements and Information	7
6.0 Check Rite and Spool Installation	8
7.0 Nameplates	8
Serial Number	8
Figure Number	8
8.0 Safety Warnings	9
9.0 Non Shock Pressure -Temperature Ratings	10
Cast Iron (ASTM A126-CLB)	10
Ductile Iron (ASTM A395)	10
Carbon Steel (ASTM A216-WCB)	10
Stainless Steel (ASTM A351-CF8M)	11
 Illustrations	
2" - 12" Series 125/150/300 Model 210	12
14" - 42" Series 125/150 Model 210	13
Stud Dimensions E-8 ANSI Series 125 - 1500	14
Spool Dimensions E-9 ANSI Series 125 / 150 / 300	15



1.0 Introduction to Check Rite Wafer Type Swing Check Valves

Modern piping applications demand better features, performance and economy in a check valve.

Features:

- Simplicity
- Compactness
- Minimum Weight

Performance Characteristics:

- Silent operation
- Non Slamming
- Rapid Response
- Low Pressure Drop
- Bubble Tight Shut-Off

A combination of these features and performance characteristics ensure long service life as characterized by Check Rite.

2.0 Description of Check Rite Valves.

Check Rite valves consist of a compact Body (1) with a single plate Disc (12) attached to a Hinge (2) which in turn is supported by a Hinge Pin (7) inside an off-center body cavity.

The Disc is mechanically biased to the closed position by a torsional Spring (5) located between the two hinge lugs. The Hinge Pin (7) is retained by two NPT Pipe Plugs (8) inside the Body (1). The Seat (3) can be:

- Metal to Metal
- Metal to Buna, Viton or Teflon

An Eyebolt (10) located on the top of the Check Rite valve aids for easy installation.

The Nameplate (11) located on the top pad specifies:

- Size
- Serial Number
- Figure Number (Pressure Class and Materials)
- Ritepro Corporation

Check Rite valves are designed to open when a pressure of less than 1 psi (.07 bar) is applied across the face of the Disc (12).

Check Rite valves are provided for installation inside the bolt circle and between standard flanges, using a suitable gasket for the application, or as specified.



Check Rite valves are normally installed with the Eyebolt pointing vertically upwards in a horizontal run of pipe, with the arrow on the Body pointing in the direction of flow.

For vertical pipe run applications, the flow direction is the only orientation required in a straight length of pipe.

All Check Rite valves are hydrostatically tested in accordance with MSS-SP-61 test procedures and zero leakage criteria.

In addition a "Zero Head Leakage" test is performed, where the Check Rite valves are placed in a horizontal position (see sketch) with the flow direction pointing vertically upwards.

An internal hydrostatic pressure equivalent to the head of water which can be retained within the downstream portion of the valve body is applied. During this one hour test, no leakage is allowed.

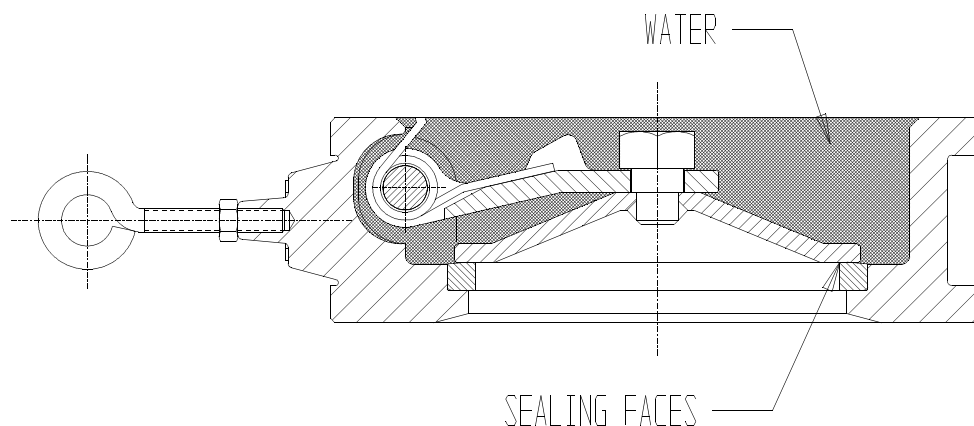

Check Rite valves are manufactured to high quality levels as specified in the applicable standards such as ANSI, MSS, API and CSA.

Check Rite valves in sizes 14" to 42" in classes 125 to 300 and all sizes in the higher pressure classes have a different Hinge-Disc connection which is illustrated on the applicable Specification Sheets.

The standard connection for small valves 2" to 12" classes 125 to 300 is a welded assembly, by means of a Shoulder Pin (4) passing through the Hinge (2) and Seal-welded to the Disc (12). In the larger sizes and higher pressure classes, the Disc (12) is assembled to the Hinge (2) with a Nut (15) and secured by welding.

A heavy duty Hinge (2) is available for valves sizes 2" to 24" in which the Disc (12) is attached to the Hinge (2) with a Nut (15) and a weld is used to secure the components. This is the Model 260 valve. All other dimensions, maintenance procedures, and O-Ring sizes apply as stated in this manual.



3.0 **Dis-Assembly and Assembly Instructions for Check Rite Wafer Type Swing Check Valves**

The simple design of the Check Rite valve permits for easy assembly and disassembly.

The following assembly procedure applies to all Check Rite valves.

To Dis-assemble the valve:

- a) Place the Body (1) in a horizontal position with the disc assembly showing.
- b) Remove the Plugs (8) on either side of the Body (1).
- c) Hold the Spring (5) in position and slide the Pin (7) out of the Body (1).
- d) Slowly release the pressure on the Spring (5) and remove it from the valve.
- e) The Hinge-Disc Assembly can now be lifted from the Body (and disassembled, if required, on large sizes).
- f) Remove the Spacers (6).
- g) Remove the O-Ring (14) if required.

To re-assemble the valve:

- a) Clean all parts with Varsol or other acceptable solvent.
- b) Place the Body (1) in a horizontal position with the seating face pointing upwards.
- c) If required, insert O-Ring (14) in the seat groove. (See next page for installation instructions).
- d) Place the Hinge-Disc Assembly (2,12) in the body cavity.
- e) Insert the Pin (7) through the plug hole on either side of the Body and slide a Spacer (6) in between the Body (1) and adjacent hinge lug.
- f) Press Torsion Spring (5) between the hinge lugs and body cavity, then advance the Pin (7) through the Spring (5) and the second hinge lug.
- g) Slide the second Spacer (6) between the Body and hinge lug and advance the Pin (7) into the Body (1).

Position the Hinge Pin (7) central to the valve body prior to the installation of the retaining Plugs (8).

- h) Check that the torsion spring ends are seated properly.
- i) Apply Teflon tape or sealing compound on retaining Plugs (8), install Plugs and tighten both sides with an Allen key.
- j) **Check:**
 - aa) that the valve opens and closes freely.
 - bb) that adequate freedom of movement of the Shoulder Pin-Disc connection is provided for the disc to adapt a self-aligning position with the seat.



IMPORTANT-INSERT O-RING AS FOLLOWS

- aa) Place O-Ring (14) on top of seat groove.
- bb) To prevent looping, insert the O-Ring as shown by pressing the O-Ring into the groove in the following numerical sequence.

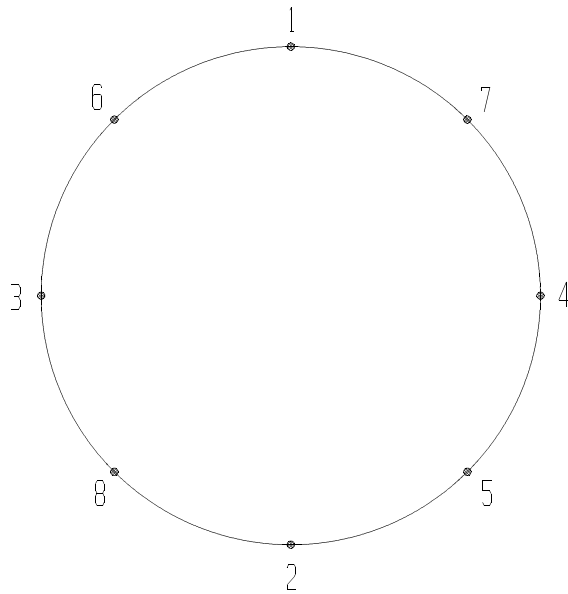

Right

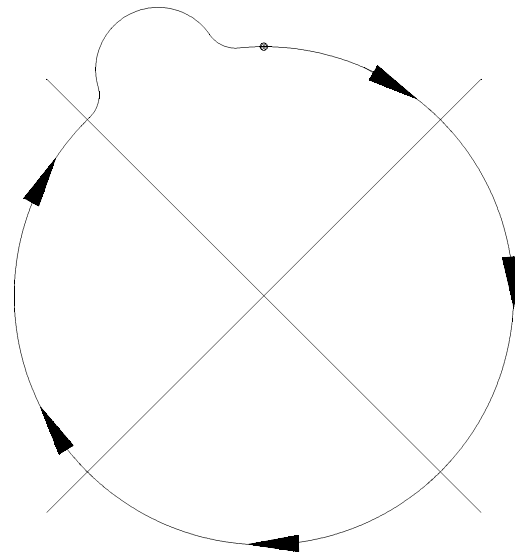

Wrong

- cc) Having engaged the O-Ring in the groove according to the above illustration, proceed to smooth out the O-Ring using thumb pressure.

It is important to smooth out the O-Ring so that there are no visible ripples or loops.

It should be noted that the O-Ring groove is slightly larger than the O-Ring and it follows that the O-Ring must be hoop stretched to engage the groove.



4.0 Installation Instructions

The stud selection sheet (Specification Sheet E-8) shows the ease with which Check Rite valves are installed.

The valve is inserted between two companion flanges with gaskets on the contact faces. Studs are installed, which will span the valve, and tightened in the same manner as any flange connection.

The Check Rite valve outside diameter is designed to locate the valve in the same centerline as the companion flanges when mounted inside the studs.

The normal installation of a Check Rite valve is for horizontal flow with the hinge pin (7) in the horizontal upper position, or for vertical flow, with the flow direction upwards.

When removing a Check Rite valve from the line, only one half of the studs need to be removed and the others loosened.

IMPORTANT:

- 1) Check the flow arrow on the body before inserting the Check Rite valve between the flanges.
- 2) Pipeline flanges must be parallel and have the same pressure class rating as the valve.
- 3) There must be no obstructions in the flange or pipe bore as this would prevent the valve from opening fully.

If slip-on flanges are used, make sure that no weld projects into the pipe bore.



5.0 Maintenance Requirements and Information

No periodical maintenance work is required for Check Rite valves. For replacement of O-Rings refer to Section 3.0, "Assembly and Dis-assembly of Check Rite Valves".

The standard O-Ring numbers, Plug sizes and Allen key sizes for class 125/150/300 are listed below for valves 2"-42". For other classes, contact the factory.

Valve Size	O-Ring Size Models 210	O-Ring Size Models 212	Plug Size NPT	Allen Key Size
2"	128	128	1/4"	1/4"
2.5"	133	133	1/4"	1/4"
3"	141	141	3/8"	5/16"
4"	235	235	3/8"	5/16"
5"	242	242	3/8"	5/16"
6"	248	248	3/8"	5/16"
8"	259	259	1/2"	3/8"
10"	368	368	1/2"	3/8"
12"	447	447	3/4"	9/16"
14"	449		3/4"	9/16"
16"	453		3/4"	9/16"
18"	455		3/4"	9/16"
20"	458		1"	5/8"
24"	462		1"	5/8"
30"	471		1 1/2" *	1 1/4" *
36"	473		1 1/2" *	1 1/4" *
42"	3/8 x110"		2" *	1 5/16" *

* Square Head Plug



6.0 Check Rite and Spool Installation

As shown on Specification Sheet E-9, when a standard flanged valve is replaced with a wafer valve, a spool piece can be inserted with the Check Rite valve to obtain the required face to face dimension.

The installation instructions in Section 4.0 above apply.

7.0 Nameplates

Serial Number

The serial number gives the style of the valve internals and the date of manufacture of the valve.

The valve internals are based on either model 210 or 212. The first two digits of the serial number give the model.

82	Model 210
88	Model 212

For standard valves, the date of assembly is included in the Serial Number stamped on the nameplate attached to the valve. The last four digits of the serial number are the month and year of manufacture.

For UL/FM valves, the serial number is specified by UL and can be any numeric value. These valves are identified by the red paint and a special nameplate is used which includes the UL and FM logos. These valves are always based on Model 212.

A unique serial number is given to all special valves (not UL/FM). For special valves (including UL/FM) the month and year of manufacture are either stamped on the nameplate or on the exterior diameter of the flange, depending on valve size.

Figure Number

The figure number consists of at least five alphanumeric characters. The first two give the class of the valve. The next three give the principle materials of construction.

If the valve has a special model number, ie Model 260, this is stamped at the end of the code or if space prohibits this, then either underneath the code or on the outside diameter of the flange. The table on the following page explains the codes used.

UL/FM valves have either 212 or 312 for a figure number. The materials of construction are always cast iron body, buna seat, stainless internals and Teflon spacer. The applicable specification sheet gives more detailed information.



Valve Class	125	150	300	600	900	1500
Code	12	15	30	60	90	150

Body Material	Cast Iron	Ductile Iron	Steel	Stainless Steel
Code	C	D	S	X

Seat Material	Buna N	EPDM	Stainless Steel	Viton
Code	B	E	M	V

Spacer Material	Teflon	Bronze	Stainless Steel
Code	T	Y	Z

For example a class 150 check valve with a ductile iron body, stainless steel seat and Teflon spacers would be stamped: **15DMT**

8.0 Safety Warnings

1. The valve must be installed in the correct line size between flanges of the correct class.
2. The valve materials of construction must be compatible with the fluids being handled.
3. Pressures and temperatures must be kept within the limits specified by the appropriate ANSI standard, ie: B16.1, B16.34, B16.42, or within the limits specified by the particular design. These values are given on the following pages.
4. An arrow on the body indicates the direction of flow through the valve. The valve must be installed with the arrow pointing in the correct direction.
5. For flow in the horizontal direction, the valve shall be installed with the Pin in the horizontal upper position with the eye bolt pointing vertically upwards.
6. The valve must be installed in the correct location in the pipeline. The disc must not open into or against other piping components such as valves, elbows, or tees. For the best performance and life of the valve, a minimum of 10 pipe diameters of straight pipe upstream and downstream of the valve is suggested. Any reduction in this length upstream of the valve reduces the life of the valve proportionally.
7. Plugs must not be removed from the valve while the pipeline is under pressure.
8. Flow rates must be within acceptable limits. Too high a rate may cause extreme pressure drops and erosion of the components. Too low a flow may cause the disc assembly to oscillate and cause wear which may lead to premature failure of the internals.
9. Care should be taken in handling the valve. Mishandling may lead to damage of the sealing components or damage to the externals.



9.0 Non Shock Pressure -Temperature Ratings

All temperatures in °F and pressures in psi.

Cast Iron (ASTM A126-CLB) Ratings from ANSI B16.1.
Class 125

Size	Temperature											
	-20 to 150	200	225	250	275	300	325	353	375	406	425	450
1"-12"	200	190	180	175	170	165	155	150	145	140	130	125
14"-24"	150	135	130	125	120	110	105	100				
28" to 48"	150	115	100	85	65	50						

Ductile Iron (ASTM A395) Ratings from ANSI B16.42.
Class 150

Size	Temperature						
	-20 to 100	200	300	400	500	600	650
2"-42"	250	235	215	200	170	140	125

Carbon Steel (ASTM A216-WCB)
Ratings from ANSI B16.34.
Permissible, but not recommended for prolonged usage above about 800°F.

Temperature	Pressure Class				
	150	300	600	900	1500
-20 to 100	285	740	1480	2220	3705
200	260	675	1350	2025	3375
300	230	655	1315	1970	32780
400	200	635	1270	1900	3170
500	170	600	1200	1795	2995
600	140	550	1095	1640	2735
650	125	535	1075	1610	2685
700	110	535	1065	1600	2665
750	95	505	1010	1510	2520
800	80	410	825	1235	2060
850	65	270	535	805	1340
900	50	170	345	515	860
950	35	105	205	310	515
1000	20	50	105	155	260



Stainless Steel (ASTM A351-CF8M)
Ratings from ANSI B16.34.

Temperature	Pressure Class				
	150	300	600	900	1500
-20 to 100	275	720	1440	2160	3600
200	240	620	1240	1860	3095
300	215	560	1120	1680	2795
400	195	515	1030	1540	2570
500	170	480	955	1435	2390
600	140	450	905	1355	2255
650	125	445	890	1330	2220
700	110	430	865	1295	2160
750	95	425	845	1270	2110
800	80	415	830	1245	2075
850	65	405	810	1215	2030
900	50	395	790	1180	1970
950	35	385	775	1160	1930
1000	20	365	725	1090	1820
1050		360	720	1080	1800
1100		325	645	965	1610
1150		275	550	825	1370
1200		205	410	620	1030
1250		180	365	545	910
1300		140	275	410	685
1350		105	205	310	515
1400		75	150	225	380
1450		60	115	175	290
1500		40	85	125	205

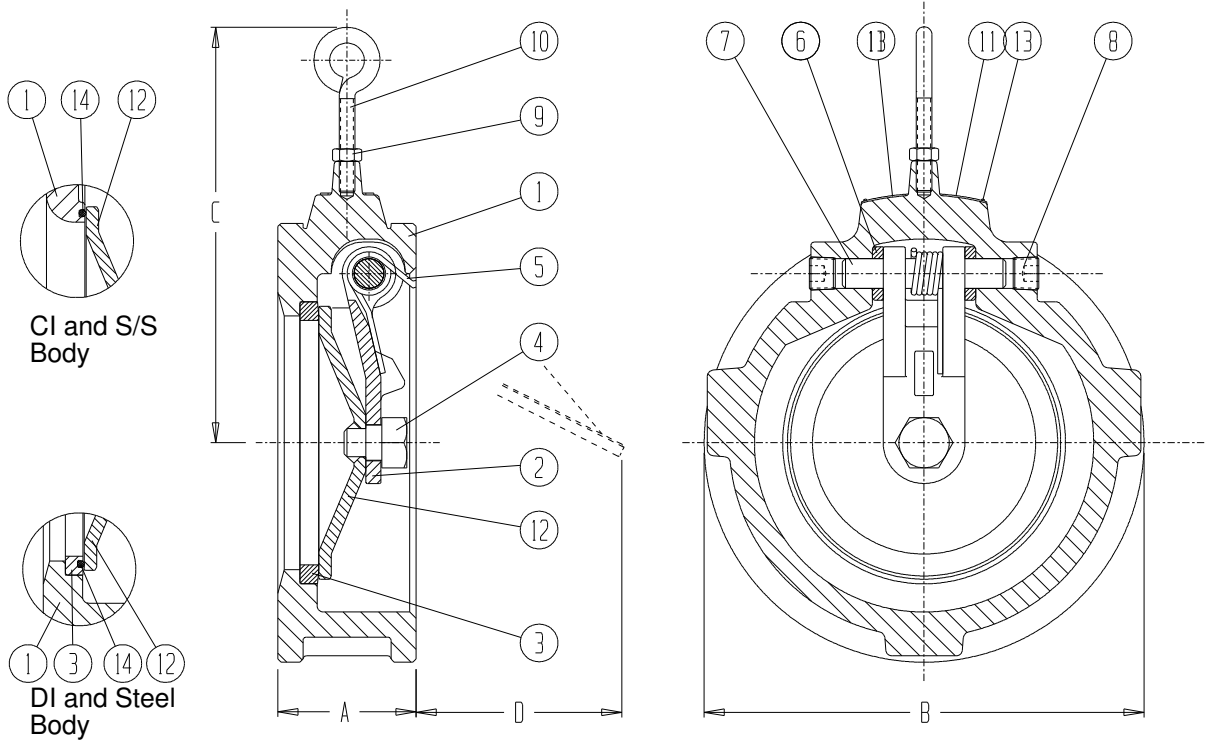

Item	Description	Standard Material
1	Body	ASTM A216-WCB
2	Hinge	ASTM A351-CF8M
3	Seat	ASTM A351-CF8
4	Shoulder Pin	ASTM A479-316
5	Spring	ASTM A313-316
6	Spacer	ASTM A479-316, Teflon
7	Pin	ASTM A479-316

Item	Description	Standard Material
8	Plug	Steel
9	Lock Nut	Steel Zinc Plated
10	Eye Bolt	Steel Zinc Plated
11	Name Plate	Aluminium
12	Disc	ASTM A240-316
13	Rivet	Steel Cad. Plated
14	O-Ring	Buna N, Viton, Teflon

Other body materials available: A126-CLB, A395, A351-CF8M, Monel, Alloy 20, Hastelloy, 254SMO.

Nominal Pipe Size		A		Class B 125/150		Class B 300		C		D		Weight	
Inch	mm	Inch	mm	Inch	mm	Inch	mm	Inch	mm	Inch	mm	lbs	kg
2	50	1.75 *	44.5	4.13	104.8	4.38	111.1	4.25	108	1.19	30	3.5	1.6
2 1/2	65	1.88 *	47.6	4.88	123.8	5.13	130.2	4.50	114	1.50	38	5.0	2.3
3	80	2.00 *	50.8	5.38	136.5	5.88	149.2	5.00	127	1.69	43	6.5	2.9
4	100	2.25	57.2	6.88	174.6	7.13	181.0	5.75	146	2.44	62	11	5.0
5	125	2.50	63.5	7.75	196.9	8.50	215.9	6.50	165	3.38	86	15	6.8
6	150	2.75	69.9	8.75	222.3	9.88	250.8	7.25	184	4.25	108	20	9.0
8	200	2.88	73.0	11.00	279.4	12.13	308.0	8.25	210	5.38	136	30	13.6
10	250	3.13	79.4	13.38	339.7	14.25	362.0	9.63	244	7.00	178	47	21.3
12	300	3.38	85.7	16.13	409.6	16.63	422.3	10.75	273	8.13	206	70	32

* Face to face for Cast Iron Class 125: 2": 2.13"
2 1/2": 2.38"
3": 2.63"

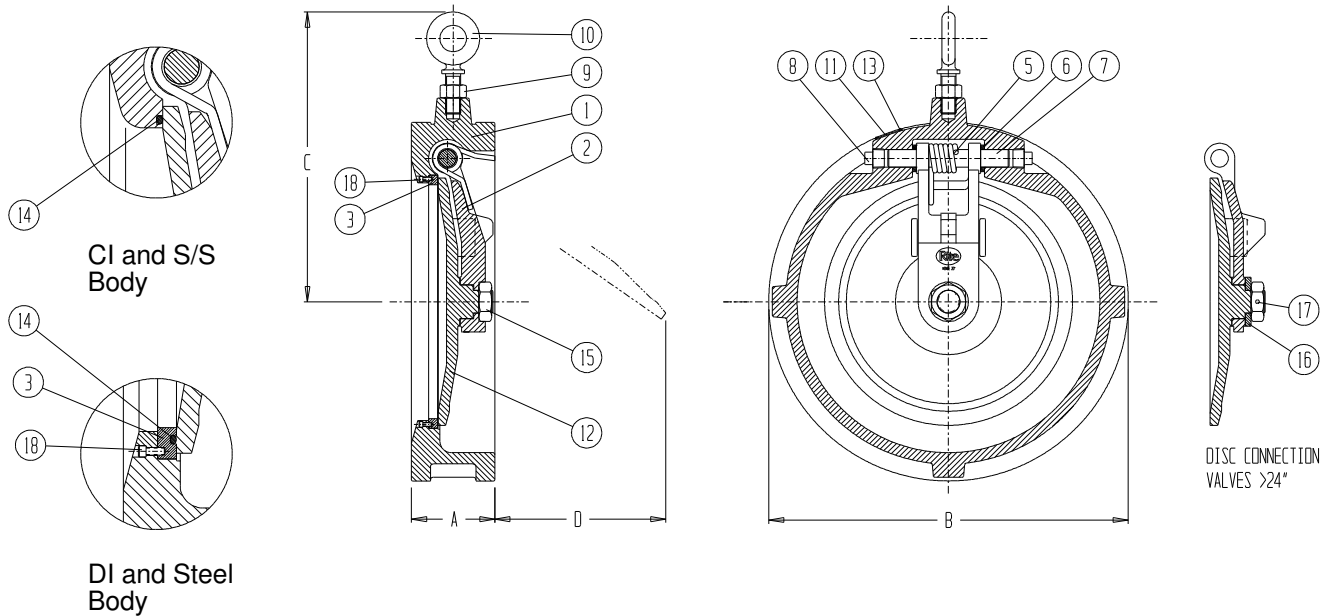

Item	Description	Standard Material
1	Body	ASTM A216-WCB *
2	Hinge	ASTM A216-WCB
3	Seat	ASTM A240-304
5	Spring	17-7PH Stainless
6	Spacer	ASTM A479-316
7	Pin	ASTM A479-316
8	Plug	Steel
9	Lock Nut	Steel Zinc Plated
10	Eye Bolt	Steel Zinc Plated

Item	Description	Standard Material
11	Name Plate	Aluminium
12	Disc	ASTM A351-CF8 **
13	Rivet	Steel Cad. Plated
14	O-Ring	Buna N, Viton, Teflon
15	Disc Nut	Steel
16	Disc Washer	Steel
17	Dowel Pin	Steel
18	SHCS	Steel

** 32" & Larger: A216-WCB with 304 overlay.

*Other body materials available: A126-CLB, A395, A351-CF8M, Monel, Alloy 20, Hastelloy, 254SMO.

Nominal Pipe Size		A		B		C		D		Weight	
Inch	mm	Inch	mm	Inch	mm	Inch	mm	Inch	mm	lbs	kg
14	350	4.25	108.0	17.63	447.7	13.00	330	7.25	184	115	52
16	400	4.25	108.0	20.13	511.2	14.50	368	8.25	210	130	59
18	450	4.25	108.0	21.50	546.1	15.25	387	10.50	267	170	77
20	500	5.50	139.7	23.75	603.3	18.75	476	11.00	280	230	104
24	600	6.00	152.4	28.13	714.4	20.50	520	15.00	381	415	188
28	700	6.50	165.1	32.50	825.5	26.13	664	17.75	451	519	235
30	750	9.00	228.6	34.63	879.5	27.50	698	16.25	412	965	438
32	800	11.00	279.4	36.75	933.5	28.25	718	14.03	356	1150	522
36	900	11.50	292.1	41.13	1044.6	30.00	762	18.25	464	1525	692
42	1050	12.00	304.8	47.88	1216.0	33.25	844	28.00	712	2235	1014

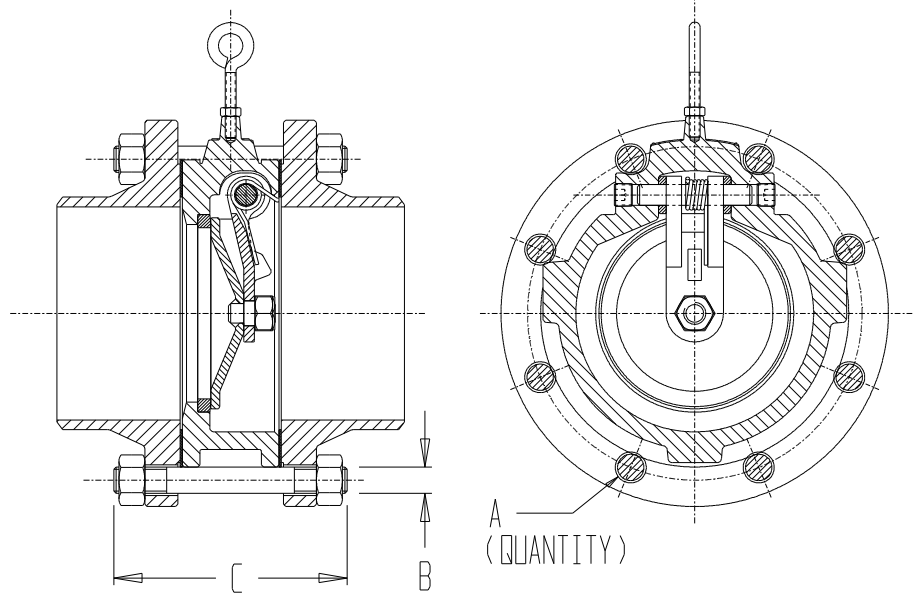

Nominal Pipe Size		Series 125 & 150			Series 250 & 300			Series 400		
		A	Stud Size B*C		A	Stud Size B*C		A	Stud Size B*C	
Inch	mm	Studs	Inch	mm	Studs	Inch	mm	Studs	Inch	mm
2	50	4	5/8*4.75	16*20	8	5/8*5.00	16*130	8	5/8*6.50	16*165
2 1/2	65	4	5/8*5.25	16*135	8	3/4*5.75	20*145	8	3/4*7.25	20*185
3	80	4	5/8*5.50	16*140	8	3/4*6.00	20*155	8	3/4*7.75	20*200
4	100	8	5/8*5.75	16*145	8	3/4*6.50	20*165	8	7/8*8.50	22*220
5	125	8	3/4*6.25	20*160	8	3/4*7.00	20*180			
6	150	8	3/4*6.50	20*165	12	3/4*7.50	20*190	12	7/8*11.25	22*285
8	200	8	3/4*7.00	20*180	12	7/8*8.25	22*210	12	1*13.00	24*330
10	250	12	7/8*7.75	22*200	16	1*9.25	24*235	16	1 1/8*15.75	28*400
12	300	12	7/8*8.00	22*205	16	1 1/8*10.00	28*255	16	1 1/4*17.00	32*435
14	350	12	1*9.25	24*235	20	1 1/8*14.00	28*280			
16	400	16	1*9.50	24*245	20	1 1/4*14.75	32*295			
18	450	16	1 1/8*10.25	28*260	24	1 1/4*15.50	32*300			
20	500	20	1 1/8*11.50	28*295	24	1 1/4*16.75	32*345			
24	600	20	1 1/4*12.75	32*325	24	1 1/2*17.75	38*385			
30	750	28	1 1/4*18.00	32*460						
36	900	32	1 1/2*19.50	38*495						
42	1050	36	1 1/2*20.50	38*520						

Nominal Pipe Size		Series 600			Series 900			Series 1500		
		A	Stud Size B*C		A	Stud Size B*C		A	Stud Size B*C	
Inch	mm	Studs	Inch	mm	Studs	Inch	mm	Studs	Inch	mm
2	50	8	5/8*6.50	16*165	8	7/8*9.50	22*245	8	7/8*9.50	22*245
2 1/2	65	8	3/4*7.25	20*185	8	1*9.50	24*245	8	1*9.50	24*245
3	80	8	3/4*7.75	20*200	8	7/8*9.00	22*230	8	1 1/8*10.25	28*260
4	100	8	7/8*8.75	22*225	8	1 1/8*10.75	28*275	8	1 1/4*11.75	32*300
6	150	12	1*12.00	24*305	12	1 1/8*14.00	28*360	12	1 3/8*16.50	35*420
8	200	12	1 1/8*14.00	28*360	12	1 3/8*16.75	35*425	12	1 5/8*19.50	35*495
10	250	16	1 1/4*16.75	32*425	16	1 3/8*18.75	35*480	12	1 7/8*23.50	48*600
12	300	20	1 1/4*17.50	32*435	20	1 3/8*21.50	35*545	16	2*27.00	50*685

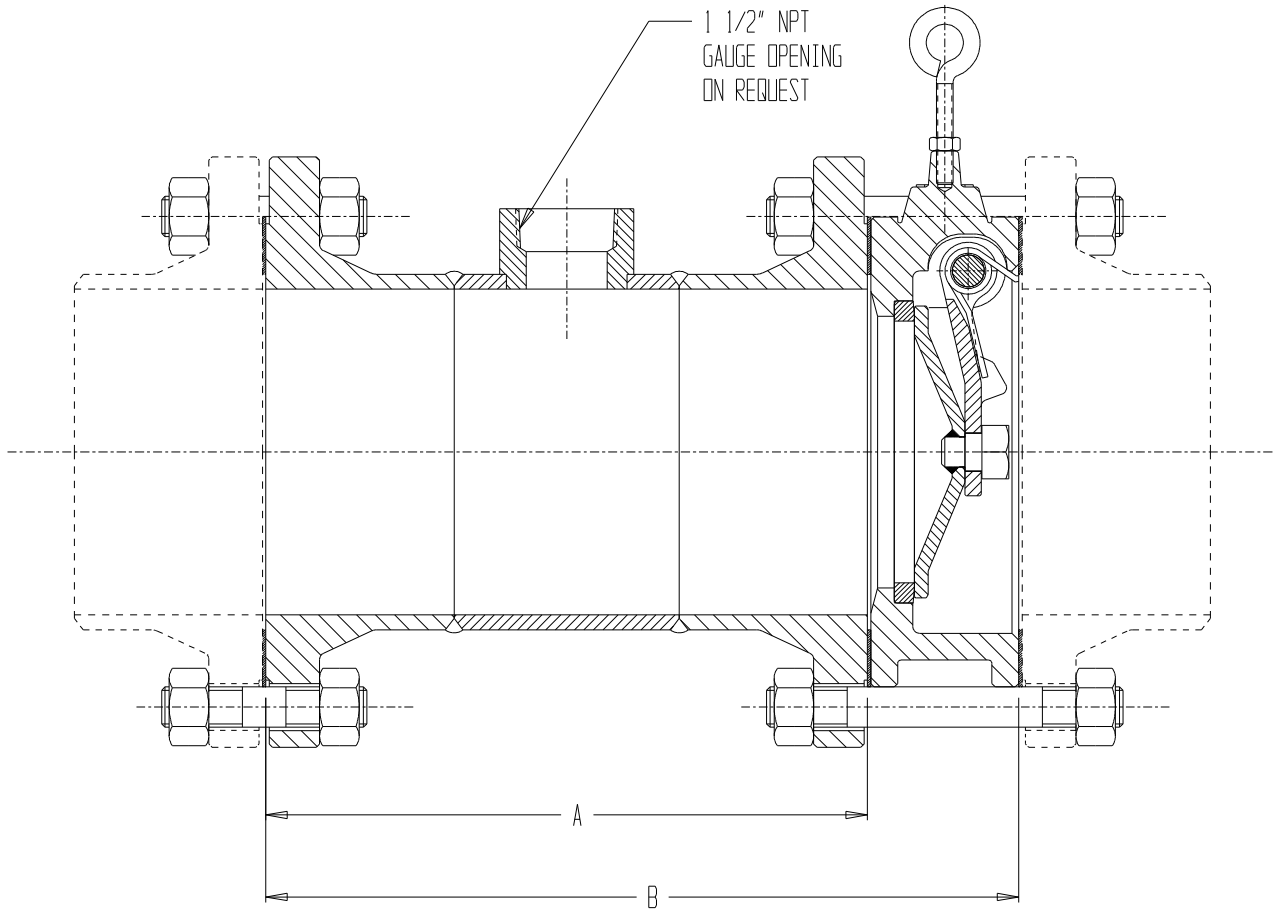

Nominal Pipe Size		Series 150				Series 300			
		A		B		A		B	
Inch	mm	Inch	mm	Inch	mm	Inch	mm	Inch	mm
2	50	6.19*	157*	8.0	203	8.69	221	10.5	267
2 1/2	65	6.56*	167*	8.5	216	9.56	243	11.5	292
3	80	7.44*	189*	9.5	241	10.44	265	12.5	318
4	100	9.19	233	11.5	292	11.69	297	14.0	356
5	125	10.44	265	13.0	330	13.19	335	15.75	400
6	150	11.19	284	14.0	356	14.69	373	17.5	445
8	200	16.56	421	19.5	495	18.06	459	21.0	533
10	250	21.31	541	24.5	622	21.31	541	24.5	622
12	300	24.06	611	27.5	699	24.56	624	28.0	711
14	350	26.69	678	31.0	787	25.69	652	33.0	838
16	400	29.69	754	34.0	864	26.44	672	34.0	864
18	450	34.19	868	38.5	978	30.44	773	38.5	978
20	500	32.94	837	38.5	978	31.31	795	40.0	1016
24	600	44.96	1141	51.0	1295	44.18	1122	53.0	1346
30	750	50.94	1294	60.0	1524				
36	900	65.44	1662	77.0	1956				

Nominal Pipe Size	Series 125	
	A	
Inch	Inch	mm
2	5.81	148
2 1/2	6.06	154
3	6.81	173

Remaining dimensions same as Series 150.

Dimension "B" corresponds to ANSI B16.10.



Ritepro Corporation
A Subsidiary of Bray International, Inc.

STANDARD SPECIFICATION SHEET
Spool Dimensions E-9
ANSI Series 125 / 150 / 300
Date: 21 September 2001

Illustrations

2" - 12" Series 125/150/300 Model 210

14" - 42" Series 125/150 Model 210

Stud Dimensions E-8 ANSI Series 125 - 1500

Spool Dimensions E-9 ANSI Series 125 / 150 / 300